

crawlspace mold?
property damage?
mildew?
musty odors?
dust mites?

Solve Crawlspace Humidity Issues for Good!

Santa Fe™
ADVANCE



Studies have shown that as much as 50% of the air in your home comes up from your basement or crawlspace. This air is often higher in moisture content, and carries with it various allergens and musty odors. When conditions linger above 60% relative humidity for extended periods of time, mold, mildew, and bacteria growth is stimulated.

The American Lung Association, American Medical Association, and the EPA recommend maintaining relative humidity level in the 30% - 50% range. Ventilation and air conditioning alone cannot provide the protection offered by a high capacity dehumidifier like the Santa Fe Advance.™ Protecting your family, and your biggest investment, is worth the best.

“APPLICATION-SPECIFIC” DESIGN

The Santa Fe Advance was specifically designed for crawlspaces. The Advance’s horizontal configuration and unique air flow perform exceptionally well in crawlspaces. The optional condensate pump and ducting kits can provide the installation flexibility necessary for almost any application. No mass-merchant dehumidifier can perform as efficiently and effectively in crawlspaces as the Santa Fe Advance.

- **Energy Star Listed:** – The high efficiency Santa Fe Advance produces over 5 pints per kilowatt-hour, far better than mass merchant dehumidifiers. Better efficiency means lower operating cost – in many cases saving hundreds of dollars a year in electricity.
- **Large Capacity** – The high capacity Santa Fe Advance provides up to 90 pints per day water removal at standard rating conditions*. Big crawlspaces (up to 2200 sq. ft.) are no problem for the Advance. This single unit can handle the challenges several mass-merchant dehumidifiers often struggle to keep up with.
- **Low Temperature Operation** – The Advance was engineered for crawlspaces, and the temperature and air flow issues that they present. When many mass-merchant dehumidifiers have stopped removing water, the Advance continues to protect family and your home.
- **Superior Air Filtration** – MERV-11 filtration is standard on the Santa Fe Advance, capturing particles (including mold spores) down to 1 micron in size. This superior level of air filtration also keeps the Santa Fe Advance working at peak efficiency for longer than other devices with cheaper designs.
- **Optional Equipment** - The engineers at Therma-Stor designed ducting and condensate pump kits for use with the Santa Fe Advance. These optional kits provide the ultimate in flexibility for your specific installation requirements.

*AHAM standard testing conditions are 80°F and 60% RH.

ADVANCE

Large capacity dehumidification



“The Santa Fe Advance was remarkably easy to install. Simply place it where you want it, plug it in and turn it on. Our crawlspace is now significantly drier with no evidence of dampness, mold or any standing water. I would highly recommend this product to anyone who has trouble with dampness in their crawlspace. It has improved the air quality throughout the house.”

— William, Richmond, VA

CONSEQUENCES OF HIGH HUMIDITY IN CRAWLSPACES

- Wet crawlspaces contribute to the cupping of wood floors and the deterioration of floor joists, beams, sub-flooring, insulation and electrical-mechanical systems.
- Excess moisture encourages mold growth on wood and on any other organic material in a crawlspace.
- Crawlspaces are a major source of air infiltration that permeates up into the living area, transmitting odors, carrying moisture, and creating an environment conducive to molds and dust mite infestation.

LARGE CAPACITY DEHUMIDIFICATION

Because basement and crawlspace floors and walls are in contact with the soil, and soil temperatures several feet below the surface remain at a constant temperature of 50°F–60°F. Basement and crawlspace floors and walls tend to remain cool. Since basements and crawlspaces tend to be cool and cool air holds less moisture than warm air, they will have higher relative humidity.

Typically, the closer to ground level, the larger the area, and the damper the environment, the more capacity that will be necessary to dry out the area. Capacity is usually measured in the number of pints of water that a dehumidifier can remove from the air at a given temperature over a given period of time.

Capacities for residential dehumidifiers are measured in pints of water removed per day at standard conditions. Standard conditions are determined by the American Home Appliance Manufacturers (AHAM) and are used because capacity will vary under different conditions. AHAM standard rating conditions are 80°F and 60% RH. The capacity of the Santa Fe Advance is 90 pints per day. Most standard residential units range from 20 to 65 pints of water removal per day. However, most basements and crawlspaces are cooler than 80°F and therefore the water removal capacity of the standard residential unit will be diminished significantly.

A large capacity dehumidifier is necessary to ensure that enough moisture is removed at the real-world temperature of your basement or crawlspace to prevent mold, mildew and bacterial growth. The Santa Fe Advance is a large-capacity dehumidifier designed for these cooler applications.

installation

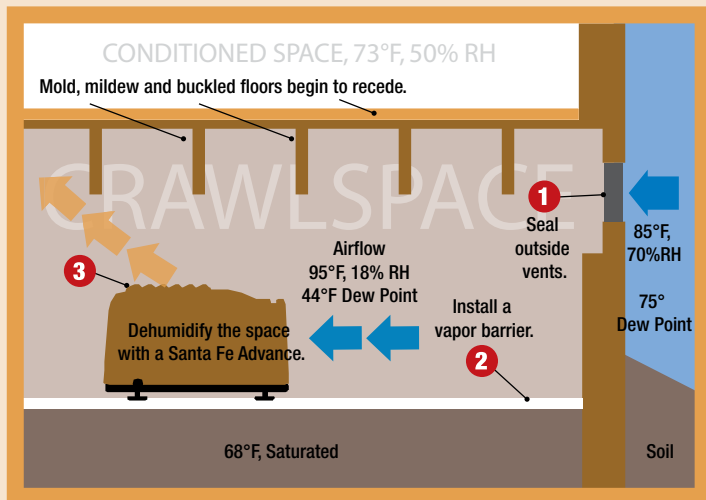

FREE STANDING INSTALLATION

Ventilation of a crawlspace to control relative humidity only works consistently in an arid climate. In most climates, ventilation can add significant quantities of moisture during humid times.

Depending on the outside weather, as much as 375 pounds of water per day can infiltrate a crawlspace through ventilation.

Proactive dehumidification of a sealed crawlspace is the only way to ensure desired humidity levels are present.

1. Seal all outside vents to eliminate outside air, which also reduces heating/cooling loads and uncontrolled moisture intake.
2. Install vapor barriers over exposed earth.
3. Condition crawlspace air with a Santa Fe Advance to provide humidity control regardless of the outside conditions.

Performance and Technical Specs

Part Number:	4025699
Blower:	240 CFM @ 0.0" WG
Power:	700 watts @ 80°F and 60% RH
Supply Voltage:	115 volt – 1phase – 60 Hz
Current Draw:	5.9 Amps
Energy Factor:	2.60 L/kWh
Operating Temp.:	45°F Min., 95°F Max.
Sized for:	2200 Sq. Ft. - Typical



Minimum Performance at 80°F and 60% RH

Water Removal:	90 Pints/Day
Efficiency:	5.5 Pints/kWh
Air Filter:	MERV-11
Efficiency:	Standard 65% Efficient, ASHRAE Dust Spot Test
Size:	Size: 12" x 12" x 1"
Power Cord:	9', 110-120 VAC, Ground
Drain Connection:	5/8" hose barb or 3/4" FPT
Drain Hose:	5/8" ID x 8' Direct Gravity Drain Hose

Santa Fe Advance Dimensions

	Unit	with Duct Kit:	Shipping
Width:	14-1/2"	14-1/2"	22"
Height:	19" w/o feet	22-1/4" w/o feet	25"
Depth:	33"	40-3/8"	39"
Weight:	71 lbs		78-1/2 lbs

OPTIONAL ACCESSORIES

4025831	Pre-Filter
4028523	Pre-Filter 12-pack
4025568	MERV 11 Filter
4027419	MERV 11 Filter 4-Pack + 1 Pre-Filter
4027425	MERV 11 Filter 12-Pack
4025845	Pump Kit
4026607	Caster Kit
4026450	Leveling Foot Kit
4026055	Duct Kit
4027415	8" Flex Duct
4020177	8" Flex Duct (Insulated)
4027430	Register Head 8"
4020126	Register Grill (White)
4020175	Dehumidistat

“I had extremely high humidity and mold in my crawlspace. The Santa Fe Advance worked flawlessly along with the optional condensate pump. Within three days the relative humidity dropped to 60% from 86% – taking out 10+ gallons of water in the first 24 hours! After two weeks the relative humidity is down to 50-53%.”

— Graddy, Huntsville, AL



Santa Fe Advance with Duct Kit, Cord and Condensate Hose

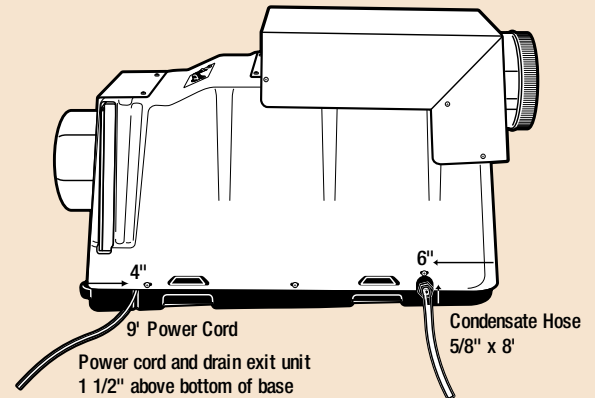

Santa Fe Advance Low-Profile Condensate Pump Kit

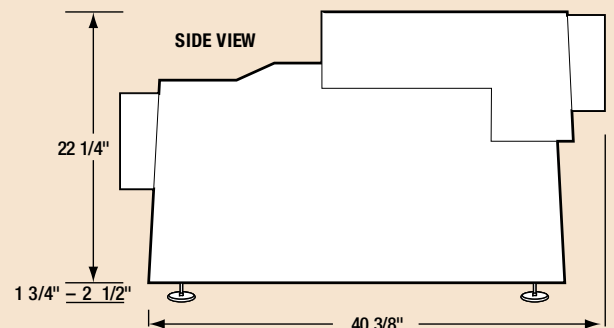
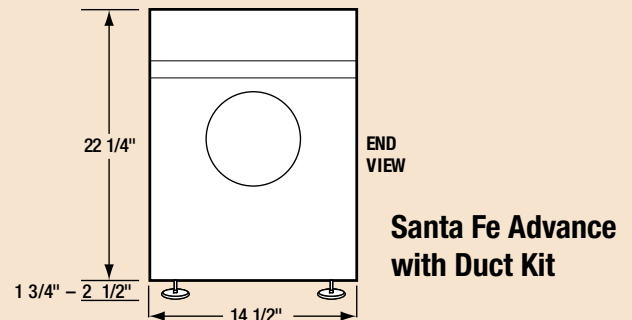
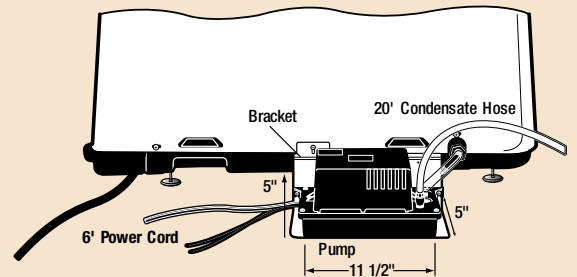

Do you know the relative humidity levels in your home?



4026208

The Humidity Alert™ was designed by Therma-Stor to discriminate between occasional periods of high humidity and the prolonged periods that create a risk of unhealthy biological activity. It's a simple, inexpensive device that monitors temperature and relative humidity conditions and records data that is known to contribute to wood rot, mold growth, musty odors and increased pest activity.

EASY TO USE:

1. Place the meter in the desired space.
2. Collect the necessary humidity data.
3. Adjust your Santa Fe dehumidifier to a desired humidity setting.

humidity alert™